

11.2801

FLANGE ROSCADA

THREAD FLANGE

PN 10 / 16

Flange

DIN EN 1092-2

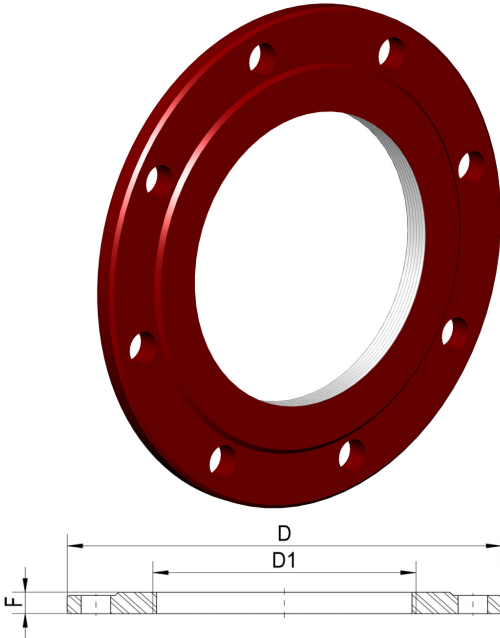

Outros diâmetros e pressões sob consulta.

Others diameters and classes on request.

| componente | material | component | material | norma | standard |
|--------------|---|-----------|---|-------------|----------|
| flange | ferro fundido dúctil (EN-GJS-500) | flange | ductile iron (EN-GJS-500) | DIN EN 1563 | |
| revestimento | tinta epóxica para águas residuais RESICOAT R4 - ES - RED BROWN aplicada electrostaticamente com espessura $\geq 250 \mu\text{m}$ | coating | epoxy paint for residual water RESICOAT R4 - ES - RED BROWN applied electrostatically with thickness $\geq 250 \mu\text{m}$ | DIN 30677 | |

| DN | Código - Code | | D | | BSP D1 (G) | F | | Ø de furação / n° e Ø dos furos hole Ø / Ø and n° of holes | | peso (Kg) weight | |
|------|---------------|----------|-------|-------|------------|-------|-------|--|-----------------|------------------|-------|
| | PN 10 | PN 16 | PN 10 | PN 16 | | PN 10 | PN 16 | PN 10 | PN 16 | PN 10 | PN 16 |
| 40 | 10133009 | 10133009 | 150 | 150 | G 1" ½ | 19,0 | 19,0 | 110Ø - 4 x 19Ø | 110Ø - 4 x 19Ø | 2.1 | - |
| 50 | 10133012 | 10113012 | 165 | 165 | G 2" | 19,0 | 19,0 | 125Ø - 4 x 19Ø | 125Ø - 4 x 19Ø | 3.1 | - |
| 60 | 10133029 | 10133029 | 175 | 175 | G 2" | 19,0 | 19,0 | 135Ø - 4 x 19Ø | 135Ø - 4 x 19Ø | 3.5 | - |
| 65 | 10133029 | 10133029 | 185 | 185 | G 2" ½ | 19,0 | 19,0 | 145Ø - 4 x 19Ø | 145Ø - 4 x 19Ø | 3.5 | - |
| 80 | 10133033 | 10133033 | 200 | 200 | G 3" | 19,0 | 19,0 | 160Ø - 8 x 19Ø | 160Ø - 8 x 19Ø | 4.9 | - |
| 100 | 10133041 | 10133041 | 220 | 220 | G 4" | 19,0 | 19,0 | 180Ø - 8 x 19Ø | 180Ø - 8 x 19Ø | 5.4 | - |
| 125 | 10133050 | 10133050 | 250 | 250 | G 5" | 19,0 | 19,0 | 210Ø - 8 x 19Ø | 210Ø - 8 x 19Ø | 5.4 | - |
| 150 | 10133064 | 10133064 | 285 | 285 | G 6" | 19,0 | 19,0 | 240Ø - 8 x 23Ø | 240Ø - 8 x 23Ø | 7.1 | - |
| 200 | 10133075 | 10133072 | 340 | 340 | G 8" | 20,0 | 20,0 | 295Ø - 8 x 23Ø | 295Ø - 12 x 23Ø | 8.8 | - |
| 250 | 10133080 | 10133081 | 400 | 400 | G 10" | 22,0 | 22,0 | 350Ø - 12 x 23Ø | 355Ø - 12 x 28Ø | - | - |
| 300 | 10133090 | 10133091 | 455 | 455 | G 12" | 24,5 | 24,5 | 400Ø - 12 x 23Ø | 410Ø - 12 x 28Ø | 17.0 | - |
| 350 | 10133095 | 10133101 | 505 | 520 | G 14" | 24,5 | 26,5 | 460Ø - 16 x 23Ø | 470Ø - 16 x 28Ø | - | - |
| 400 | 10133111 | 10133115 | 565 | 580 | G 16" | 24,5 | 28,0 | 515Ø - 16 x 28Ø | 525Ø - 16 x 31Ø | 24.0 | - |
| 450 | 10133120 | 10133125 | 615 | 640 | G 18" | 25,5 | 30,0 | 565Ø - 20 x 28Ø | 585Ø - 20 x 31Ø | - | - |
| 500 | 10133135 | 10133136 | 670 | 715 | G 20" | 26,5 | 31,5 | 620Ø - 20 x 28Ø | 650Ø - 20 x 34Ø | - | - |
| 600 | 10113140 | 10133145 | 780 | 840 | G 24" | 30,0 | 36,0 | 725Ø - 20 x 31Ø | 770Ø - 20 x 37Ø | - | - |
| 700 | 10133150 | 10133155 | 895 | 910 | G 28" | 32,5 | 39,5 | 840Ø - 24 x 31Ø | 840Ø - 24 x 37Ø | - | - |
| 800 | 10133160 | 10133165 | 1015 | 1025 | G 32" | 35,0 | 43,0 | 950Ø - 24 x 34Ø | 950Ø - 24 x 41Ø | - | - |
| 900 | 10133170 | 10133175 | 1115 | 1125 | G 36" | 37,5 | 46,5 | - | - | - | - |
| 1000 | 10133180 | 10133185 | 1230 | 1255 | G 40" | 40,0 | 50,0 | - | - | - | - |

Homologações - Homologation

Revestimento - Coating

- **KIWA** (Holanda - Netherlands)
- **WRAS** (Reino Unido - United Kingdom)
- **CARSO** (França - France)
- **STÁTNI ZDRAVOTNÍ ÚSTAV** (República Checa - Czech Republic)

Sendo um dos principais objectivos da nossa empresa o desenvolvimento e aperfeiçoamento dos nossos produtos, reservamo-nos no direito de fornecer quaisquer outros que possam diferir ligeiramente dos descritos e ilustrados nesta publicação.

Being one of our aims a constant development of our products, the characteristics of described material may be altered without prior warning.

